

REVISION HISTORY			
REV.	DESCRIPTION	DATE	DRAWN BY
1	ORIGINAL PRINT	7/27/2023	P. YEUNG

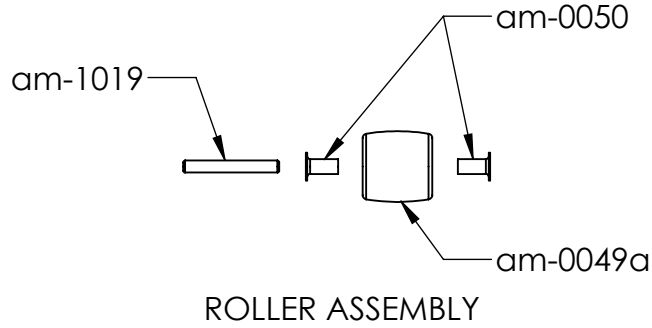

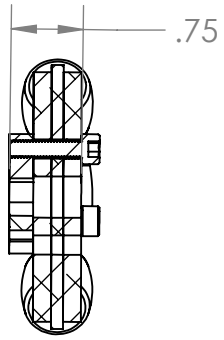
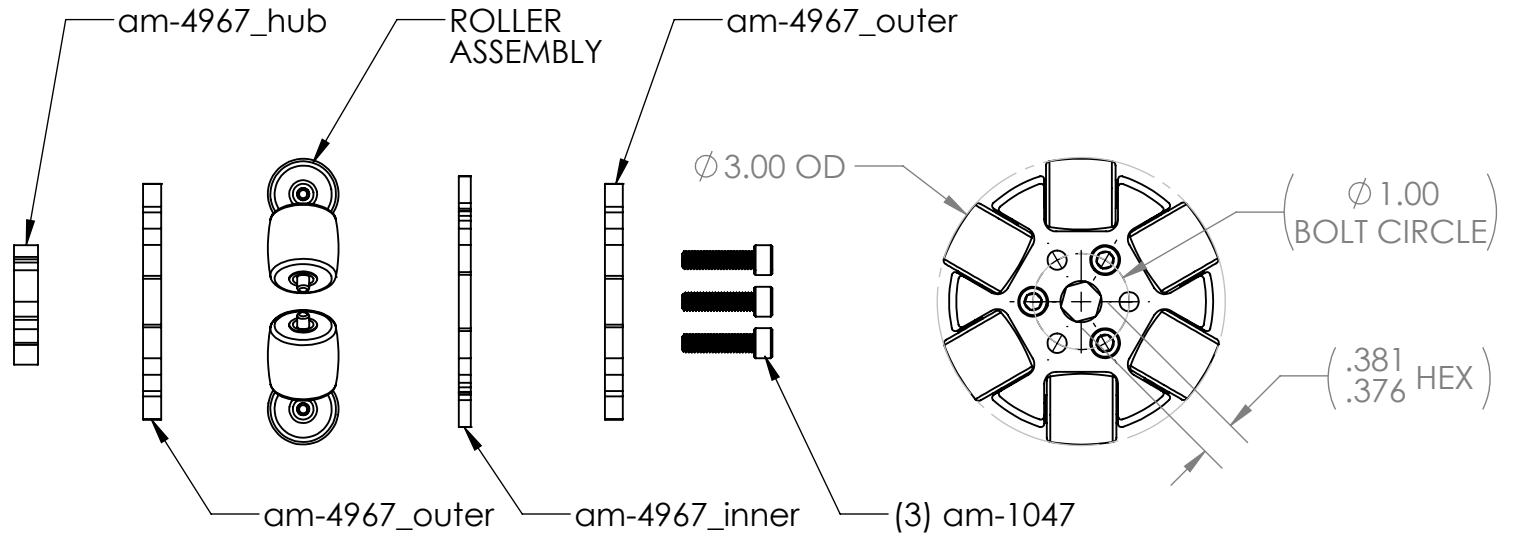
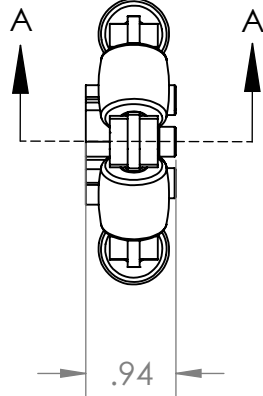

SECTION A-A

ROLLER ASSEMBLY

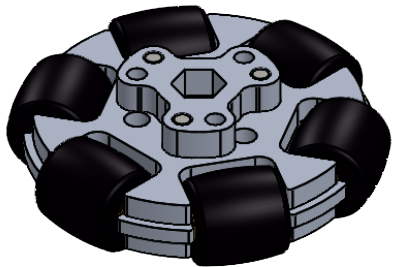

*** SEE CAD FOR ADDITIONAL TOOLPATH INFO***



UNLESS OTHERWISE SPECIFIED:		COMMENTS:				
DIMENSIONS ARE IN INCHES		DUAL DIMENSIONS ARE IN MILLIMETERS.				
TOLERANCES:		BREAK ALL SHARP EDGES.		TITLE:		
FRACTIONAL	±1/16			3IN ALUMINUM OMNI		
ANGULAR: MACH	±1°			WHEEL 375IN HEX BORE		
ANGULAR: BEND	±5°			(SINGLE)		
ONE PLACE DECIMAL	±0.1			SIZE	DWG. NO.	REV
TWO PLACE DECIMAL	±0.01	A	am-4967	1		
THREE PLACE DECIMAL	±0.005				SCALE: 1:2	
FOUR PLACE DECIMAL	±0.0005				SHEET 1 OF 1	
MATERIAL	VARIOUS	CHECKED	NAME	DATE		
FINISH		ENG APPR.	NM	8/3/23		
DO NOT SCALE DRAWING		MFG APPR.				
		Q.A.				